

Systems Engineering

Electromagnetic Compatibility

Pere Palà

iTIC <http://itic.cat>

v1.0 May 2013

Source: A significant part is from Tim Williams' *The Circuit Designer's Companion*

Electromagnetic compatibility

- ▶ Electronic gadgets
 - ▶ Generate electromagnetic interference
 - ▶ Are susceptible to electromagnetic interference
- ▶ Acceptable levels of interference are getting lower
 - ▶ Solid-state more susceptible than vacuum-tube devices
 - ▶ Many devices in close distance
 - ▶ Plastic cases
- ▶ Military: high-power pulse equipment near sensitive devices in same vehicle
- ▶ Walkie-talkies, mobile phones, WiFi-enabled devices

Importance of EMC

- ▶ Poor EMC performance when device is deployed becomes costly
 - ▶ Damaged Reputation
 - ▶ Difficult and expensive to repair
- ▶ EMC testing is important even if no legislation is available
- ▶ Device able to operate in hostile environment: immunity
- ▶ Device does not cause unreliable operation to others: emissions

Immunity / Emissions

Immunity

- ▶ Mains voltage drop-outs, dips, surges and distortion
- ▶ Transients and radio frequency interference (RFI) conducted into the equipment via the mains supply
- ▶ Radiated transient or RFI, picked up and conducted into the equipment via signal leads
- ▶ RFI picked up directly by the equipment circuitry
- ▶ Electrostatic discharge

Emissions

- ▶ mains distortion, transients or RFI generated within the equipment and conducted out via the mains supply
- ▶ transient or RFI, generated within the equipment and conducted out via signal leads
- ▶ RFI radiated directly from the equipment circuitry, enclosure and cables

Immunity: RF

- ▶ Electromagnetic environment very variable
- ▶ Fields dependent on the distance. $E \propto 1/d$ for $d > \lambda/2\pi$

$$E = \sqrt{30EIRP}/d \quad (1)$$

- ▶ Radio transmitters.
 - ▶ AM 100-500 kW. Far from equipment. $E \sim 1-10$ V/m
 - ▶ FM, TV 10 kW. May be close to offices or industries.
 $E \sim 1$ V/m after building attenuation. Difficult to shield: λ is small
 - ▶ Walkie-talkies, cellphones. Close to equipment. 1 W gives 5 V/m at 0.5 m distance
- ▶ Radars
 - ▶ 1-10 GHz, near airports. 50 V/m at 3 km
 - ▶ Pulses: hazardous for microprocessors
- ▶ 10 V/m immunity (or 3 V/m) from 10 MHz to 1 GHz

Immunity: Mains conducted transients

- ▶ Conducted transients: digital devices are more susceptible to them

Area	Transients/hour
Industrial	17.5
Business	2.8
Domestic	0.6
Laboratory	2.3

- ▶ Rate of rise, $\sim \sqrt{V_{peak}}$.
10 V/s for 2 kV pulses
- ▶ Microprocessor equipment: withstand pulses up to 2 kV

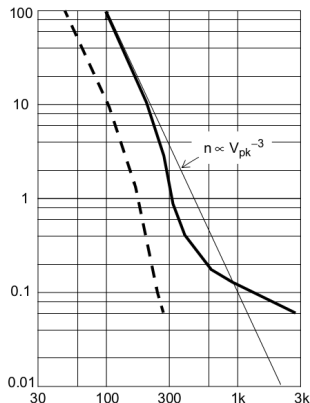

Relative number of transients vs. maximum transient amplitude
Solid: mains lines (> 100 V)
Dashed: telecomm lines (> 50 V)

Other conducted transients

- ▶ Telecommunications lines
- ▶ Lightning
 - ▶ 100 lightning strikes per second worldwide
- ▶ Automotive 12 V supply
 - ▶ Changes in alternator load
 - ▶ Switching of inductive loads

Electrostatic Discharge ESD

- ▶ Person charged to high potential
- ▶ Equivalent model: 150 pF in series with 150 Ω
- ▶ Fast pulses (sub-ns) of high current (10 A)
- ▶ Effects of ESD may be subtle or fatal

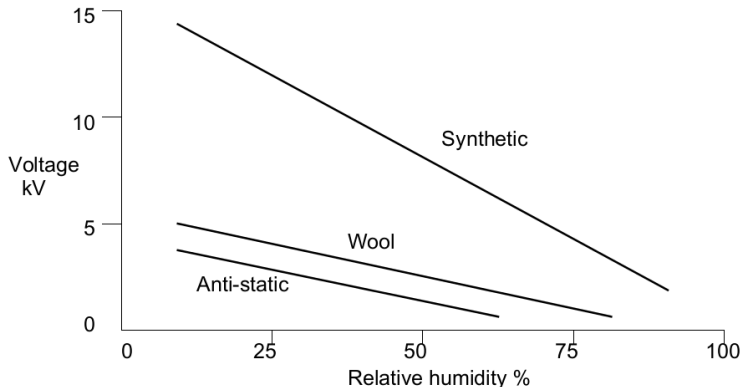

Emissions

- ▶ Generated by switching transients
 - ▶ Pulses at mains frequency
 - ▶ Switching power supply
- ▶ Digital clock or data signals
 - ▶ Digital equipment with square wave clocks: noise up to 1 GHz
 - ▶ System clock frequency and harmonics: narrow spikes
 - ▶ Wideband noise from data
 - ▶ $f < 30$ MHz: conducted via mains leads
 - ▶ $F > 30$ MHz: radiated
- ▶ Regulations assume some separation between transmitter and receiver

The EMC directive

Essential requirements

The apparatus shall be so constructed that:

- ▶ Equipment shall not generate electromagnetic disturbances exceeding a level allowing radio and telecommunications equipment and other apparatus to operate as intended
- ▶ Equipment shall have an adequate level of intrinsic immunity from electromagnetic disturbances

Standards

- ▶ Comply with standards \Rightarrow comply essential requirements
- ▶ CENELEC : European standards body
- ▶ Most standards based on IEC

Conducted measurements

► LISN: Line Stabilization Network

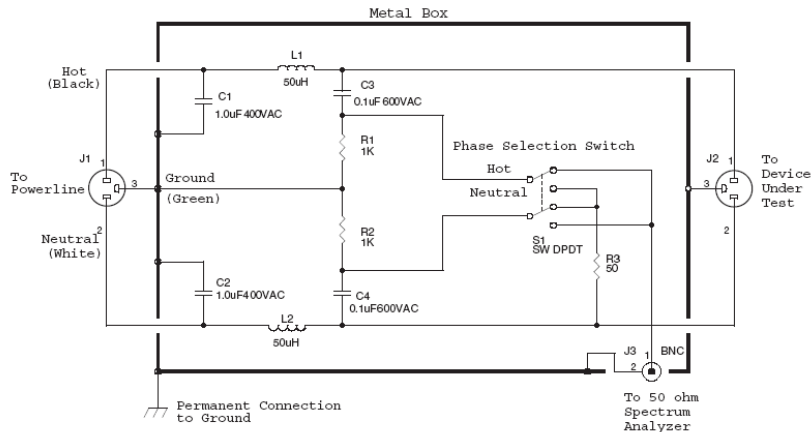
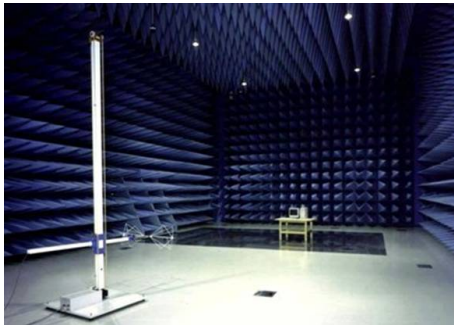

Figure 4.16 A 50Ω/50μH LISN as defined by standard CISPR16-1. This circuit provides a 50-Ω output impedance for measurement of RF emissions produced by the device under test. Conducted emission measurements are carried out from 150 kHz to 30 MHz.

Radiated measurements

- ▶ Open Area Test Site or anechoic chamber



- ▶ Measurement
 - ▶ Quasi-Peak
 - ▶ Average

Mains conducted limits

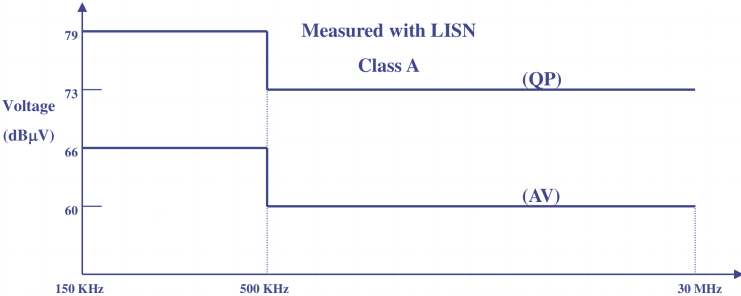
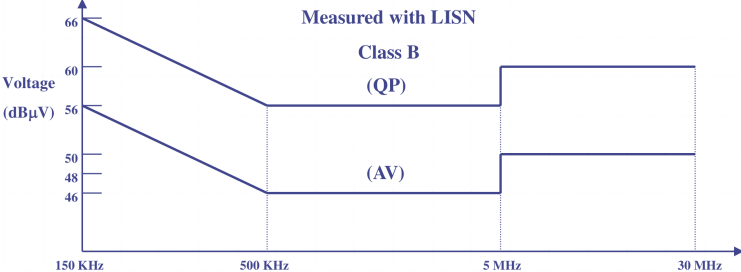

Radiated limits

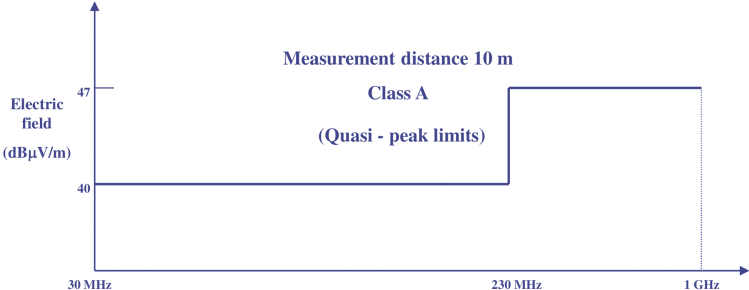
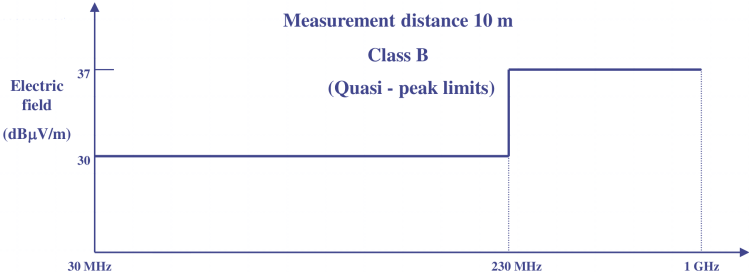

Interference coupling mechanisms

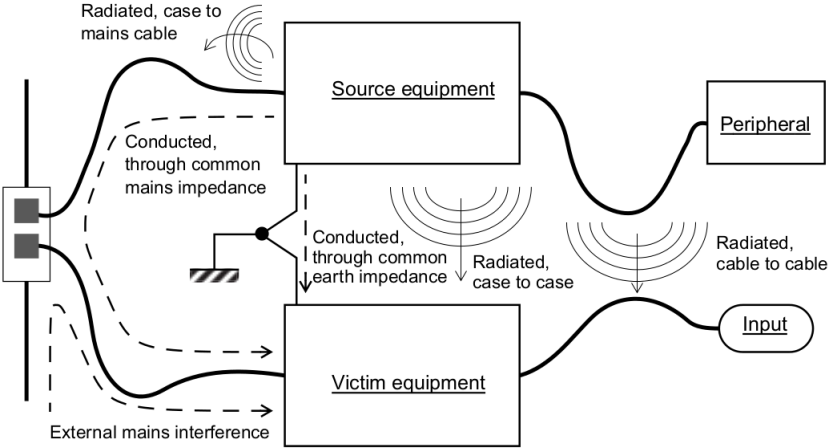

Common and differential mode propagation

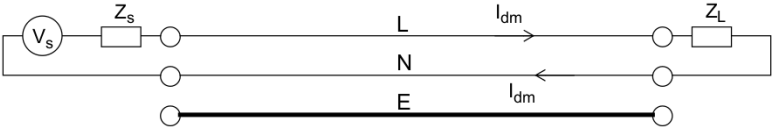

a) differential mode

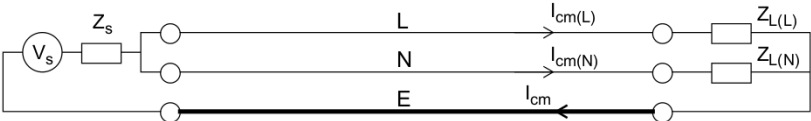

b) common mode

Design guidelines

- ▶ Shielding and filtering costs money
- ▶ Circuit design doesn't!
- ▶ Short tracks with nearby ground return or differential signaling

Digital

- ▶ Use slowest logic family

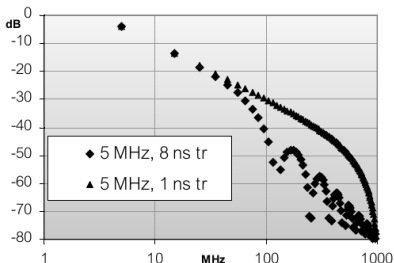
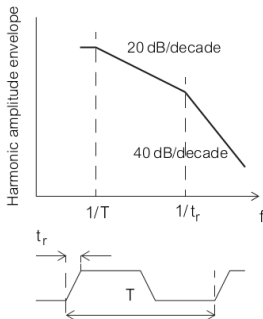

- ▶ Use lowest clock frequency
- ▶ (Clock dithering)

Design guidelines 2

Analog

- ▶ Watch out for RF oscillations (or overshots)
- ▶ Minimise signal bandwidth. RC or ferrites
- ▶ High signal level
- ▶ Balanced signals
- ▶ Galvanic isolation
- ▶ Keep the circuit linear (avoid intermodulation distortion).
Filtering cleans everything up

Design guidelines 3

Software

- ▶ Watchdog timer
- ▶ Check range of input data. Reject if outside valid range
- ▶ Oversample and average data
- ▶ Parity check
- ▶ Implement error detecting and/or correcting codes
- ▶ Rely on levels rather than on edges
- ▶ Re-initialise programmable peripherals: they *will* lose their configuration

Shielding

- ▶ Conductive surface around critical parts
- ▶ Attenuation by reflection and absorption
- ▶ All-metal (for low f) or only a conductive coating on plastic
- ▶ Typical shielding effectivity: 20–80 dB is average. > 120 dB is unachievable
- ▶ Perfect shield: seamless box of zero-resistance material with no apertures. The Faraday cage
- ▶ Practical shields
 - ▶ Are not made of perfect conductors
 - ▶ Have apertures

Shielding. Aluminium

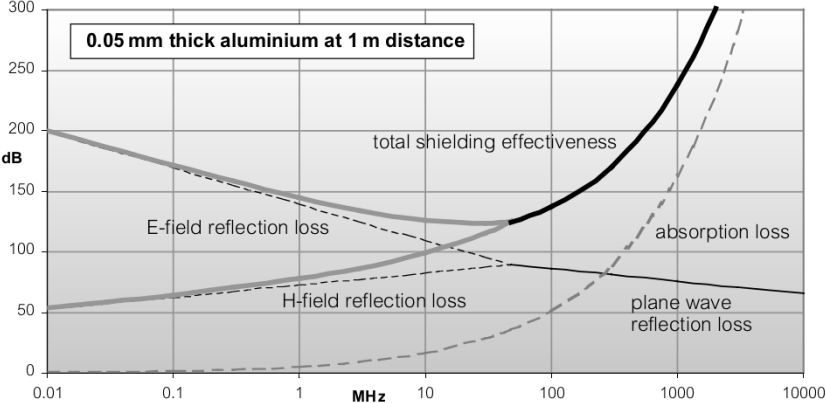

Shielding. Steel

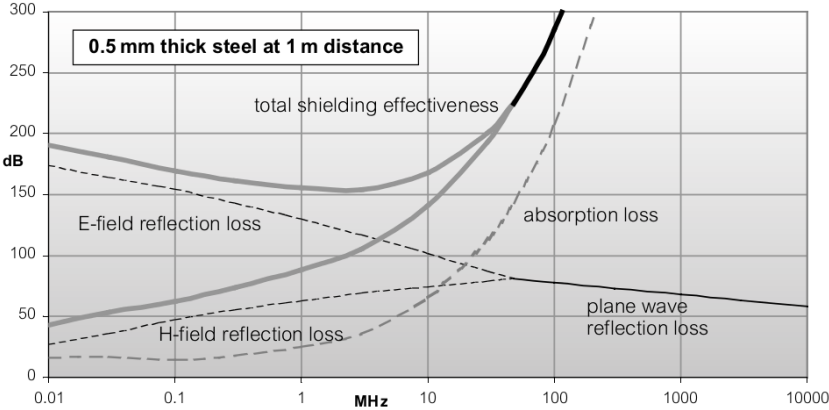

Apertures

- ▶ Practical shielding effectiveness is limited by apertures and discontinuities in shielding.
- ▶ Apertures: ventilation, indicators, ...
- ▶ Leakage depends on the longest dimension d and the minimum wavelength λ . No shielding if $\lambda < 2d$

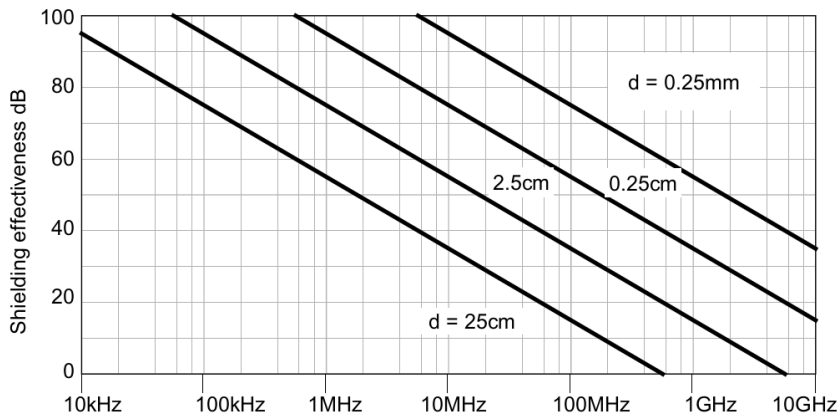

Seams

- ▶ Imperfect joints: distortion, painting, anodising, corrosion...
- ▶ Overlap: capacitor. Path for higher frequencies
- ▶ Place screws or rivets no farther than $\lambda/20$
- ▶ Conductive gasket: knitted wire mesh, conductive fabric over foam, ...



- ▶ Beryllium copper fingers

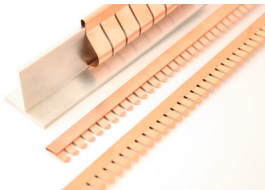

Filtering

- ▶ Low-pass filters
 - ▶ Single inductor. Works well if Z_G and Z_L are low.
 - ▶ Single capacitor. Works well if Z_G and Z_L are high.
 - ▶ LC, CL, CLC... Analysed using conventional techniques. But: source and load impedances are not exactly known!
- ▶ Provide low-inductance ground path
- ▶ Ready-made mains filters



Cables and connectors

- ▶ Cable shield to minimize the creation of external fields
- ▶ Shield has to be properly terminated. 360° contact is desirable (such as in BNC).
- ▶ Screened connector shell

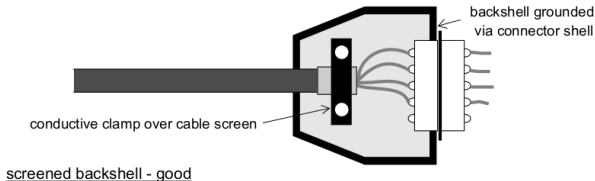
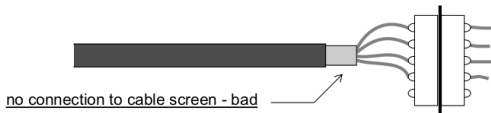

EMC checklist

Components

- ▶ use slow and/or high-immunity logic
- ▶ use good RF decoupling of power supplies
- ▶ minimise signal bandwidths with RC filtering, maximise levels
- ▶ use resistor buffering on long clock or data lines
- ▶ incorporate a watchdog circuit on every microprocessor

PCB layout

- ▶ keep interference paths segregated from sensitive circuits
- ▶ minimise ground inductance with an unbroken ground plane or ground grid
- ▶ minimise loop areas in high-current or sensitive circuits
- ▶ minimise track and component leadout lengths

EMC checklist 2

Cables

- ▶ avoid parallel runs of signal and power cables
- ▶ make sure that screens are 360 °bonded through properly designed connectors
- ▶ use twisted pair for high-speed data or high-current switching
- ▶ run internal cables away from apertures in shielded enclosures
- ▶ use multiple ground wires or planes in ribbon or flexi cables

Grounding

- ▶ ensure adequate bonding of screens, connectors, filters, cabinets etc.
- ▶ ensure that bonding methods will not deteriorate in adverse environments
- ▶ mask paint from any intended conductive areas
- ▶ keep earth straps short and wide: aim for a length/width ratio less than 3:1
- ▶ route conductors to avoid common ground impedances

EMC checklist 3

Filters

- ▶ apply a mains filter for both emissions and immunity:
check required current rating
- ▶ use correct components and filter conf. for I/O lines
- ▶ ensure good interface ground return / each filter group
- ▶ ensure filter input and output terminal wiring is kept separate
- ▶ apply filtering to interference sources, such as switches or motors

Shielding

- ▶ determine the type and extent of shielding required from the frequency range of interest
- ▶ enclose particularly sensitive or noisy areas with extra internal shielding
- ▶ avoid large or resonant apertures in the shield, or take measures to mitigate them
- ▶ use conductive gaskets where long ($> \lambda/20$) gaps or seams are unavoidable