



Pràctica 7. Filtering

A Bandpass Filter to Remove Noise from a Morse Signal.

Pere Palà

Rosa Giralt

January 2013

In this lab session we will build a bandpass filter to remove noise from a Morse coded signal.

ATTENTION: Please remember to work out individually those paragraphs looking as this one. This previous work has to be uploaded to the Atenea platform before 0:00 of the lab session day. You can also hand it in when you arrive at the laboratory.

Remember also to bring all the required tools for a hardware laboratory session (protoboard, cables, etc).

1 Signal and noise

Signals are often contaminated with noise. The most straightforward way to remove noise is to filter out all those frequencies that are not present in the signal to be processed.

In this session, we will start with a Morse signal contaminated with noise. This signal is generated from a pseudo-random generator built around a shift register which is properly fed back (you may wish to look up your class notes from *Introduction to Digital Systems*).

For this session, we will use a CPLD which is already programmed, providing a Morse signal and another signal with the pseudo-random signal (also called pseudo-noise: PN). In this session, you will have to clock the CPLD at a frequency 16 times the desired Morse pitch (i.e, around 16 kHz).

Previous Work 1. Elaborate a circuit that allows obtaining a signal that is a linear combination of both the Morse and the PN signals. Provide a way to change the coefficients of the linear combination.

Task 1. Build the circuit and experiment with different signal-to-noise ratios (SNR). Note: SNR is the quotient S/N , with S being the signal power and N the noise power.

2 Bandpass Filter

For convenience, in this session we will make use of the UAF42 integrated circuit. The UAF42 allows to build low-pass, band-pass and high-pass filters operating at frequencies up to 100 kHz. The main advantage of this integrated circuit is the availability of tight-tolerance and

low-loss capacitors. If the requirements of the filter are not very stringent, the same circuit may be implemented with discrete components at a fraction of the cost.

Figure 1 depicts one of the possible structures that may be used. Note that there are only four external elements: R_{F1} , R_{F2} , R_G and R_Q .

Previous Work 2. Compute the three transfer functions of the circuit in figure 1. Describe explicitly the dependence of

- the constant term,
- ω_0 ,
- and $Q = 1/(2\xi)$

with the circuit element values. Consider $C_1 = C_2 = C$, $R_{F1} = R_{F2} = R_F$, $R_1 = R_2 = R_4 = R_G = R$. The value of R_Q is kept free.

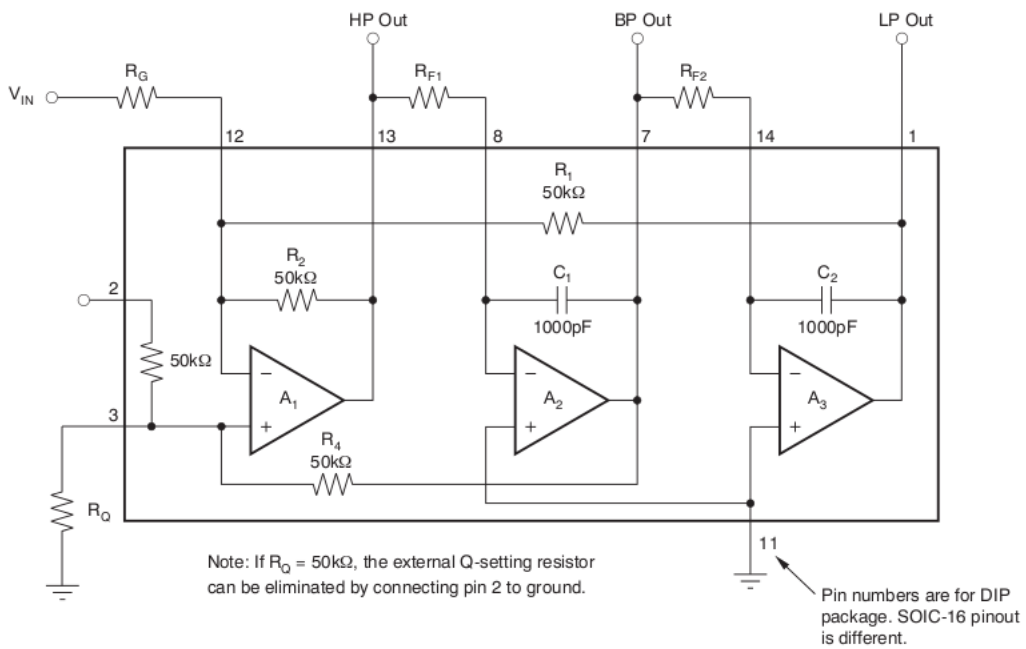

Design Equations

| | |
|---|--|
| <p>1. $\omega_n^2 = \frac{R_2}{R_1 R_{F1} R_{F2} C_1 C_2}$</p> <p>2. $Q = \left(1 + \frac{R_4}{R_Q}\right) \frac{1}{\left[\frac{1}{R_1} + \frac{1}{R_2} + \frac{1}{R_G}\right]} \left[\frac{R_{F1} C_1}{R_1 R_2 R_{F2} C_2}\right]^{1/2}$</p> <p>3. $QA_{LP} = QA_{HP} \left(\frac{R_1}{R_2}\right) = A_{BP} \left[\frac{R_1 R_{F1} C_1}{R_2 R_{F2} C_2}\right]^{1/2}$</p> | <p>4. $A_{LP} = \frac{R_1}{R_G}$</p> <p>5. $A_{HP} = \frac{R_2}{R_1} A_{LP} = \frac{R_2}{R_G}$</p> <p>6. $A_{BP} = \left(1 + \frac{R_4}{R_Q}\right) \frac{1}{R_G \left[\frac{1}{R_1} + \frac{1}{R_2} + \frac{1}{R_G}\right]}$</p> |
|---|--|

Figure 1: Schematic from the UAF42 datasheet.

Previous Work 3. Confirm that it is possible to adjust ω_0 and Q in an independent way. This ability is called *orthogonal adjustment* and is a desired feature that requires a specific circuit structure.

Previous Work 4. Find the amplification of the three transfer functions at $\omega = \omega_0$

Task 2. Build the circuit in figure 1 with suitable values of R_F such that $f_0 = 1$ kHz. Use a potentiometer for R_Q to achieve values of Q between 20 and 80.

Task 3. Generate a sinusoidal input signal and measure the resonant frequency and the -3 dB filter bandwidth (use the BP output). Discuss the coherence of these results.

Task 4. Switch the input signal to a square wave and explore what happens with the output signal for input frequencies of 1 kHz and $1/n$ kHz with $n = 1, 2, 3, 4, 5$.

3 Removing noise

Now, we are ready to hear the effect of a high- Q filter on the input signal contaminated with noise!

Task 5. Use the PN signal as the input of the filter. Listen to the filter input and output and explain what you hear.

Task 6. Now, use the combination of PN and noise signal as the input of the filter. Again, listen to the filter input and output.