

Pràctica 5. Negative Resistance Oscillator

Sine wave generation with a LC circuit.

Pere Palà

Rosa Giralt

November 2012

In this lab session we will build an oscillator compensating the losses of a real LC circuit with an active circuit that exhibits negative resistance. This approach may be used to generate signals up to the GHz range.

ATTENTION: Please remember to work out individually those paragraphs looking as this one. This previous work has to be uploaded to the Atenea platform before 0:00 of the lab session day. You can also hand it in when you arrive at the laboratory.

Remember also to bring all the required tools for a hardware laboratory session (protoboard, cables, etc).

1 Basic Theory

The circuit depicted in figure 1 is able to produce a sine wave, as any transfer function that may be defined—for instance the impedance between the terminals shown— has a denominator polynomial of the form $s^2 + \frac{1}{LC}$.

Previous Work 1. Considering that the capacitor voltage at $t = 0$ is V_M , calculate the resulting waveform for $t > 0$ in the circuit shown in figure 1.

In practice, however, the response is observed to decay due to different energy dissipation mechanisms. The most significant energy loss is due to the resistance inherent to any real inductor.

Hence, a more detailed model of a parallel connection of a capacitor and a *real* inductor is depicted in figure 2.

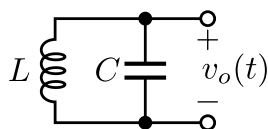

Figure 1: Parallel LC circuit.

Previous Work 2. Considering the circuit in figure 2 with $r = 30 \Omega$, $L = 22 \text{ mH}$ and $C = 100 \text{ nF}$, compute the resulting waveform $v_o(t)$ considering that a voltage source of V_M Volt was connected across the terminals shown during $t < 0$.

To compensate the overall circuit losses, a negative resistance may be connected across the circuit terminals, as shown in figure 3.

Previous Work 3. Compute the input impedance $Z(s)$ and show under which conditions the circuit may behave as an oscillator. Indicate the value of R that makes the circuit marginally stable for the element values given in previous work 2. We will call this value R_0 .

Previous Work 4. Make a sketch of the free response of the circuit for $R = 0.9R_0$ and $R = 1.1R_0$. In particular, indicate the frequency and the time constant of the waveforms.

In practice, one of the design criteria is to ensure that the circuit is initially unstable, as this ensures oscillator startup. However, $v_o(t)$ can not grow till infinity. Thus, we have to investigate the mechanism that limits signal growth. This is strongly dependent on the particular circuit that is used to build the negative resistance.

In this lab session, we will implement a negative resistance with the circuit in figure 4.

Previous Work 5. Considering $R_2 = R_1$, verify that the input impedance of the circuit in figure 4 is $-R$, provided that the OpAmp is operating in its linear region, i.e. there is a virtual short between the input terminals.

In practice, the negative resistance behavior can only be achieved within a limited interval. The active elements required to achieve such behavior (the presence of active elements is mandatory as a negative resistor is able to *generate* power) stop behaving actively for sufficiently high signals.

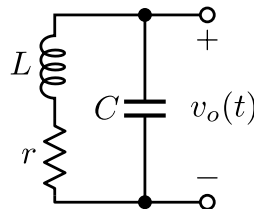

Figure 2: Parallel LC circuit with inductor losses.

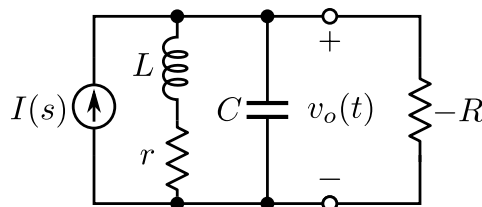

Figure 3: A negative resistance is included to compensate losses.

Previous Work 6. Considering that the OpAmp saturates at ± 13.5 V and taking $R_2 = R_1 = 1$ k Ω and $R = R_0$, compute the values of V_p for which the OpAmp saturates.

So, for sufficiently high values of V_p , the equivalent circuit is not a negative resistance but the Thevenin equivalent shown in figure 5.

Hence, the resulting i - v characteristic becomes a piecewise linear function such as depicted in figure 6.

Previous Work 7. Considering that the OpAmp saturates at ± 13.5 V and taking $R_2 = R_1 = 1$ k Ω and $R = R_0$, compute the whole $i = f(v)$ curve of the circuit in figure 4.

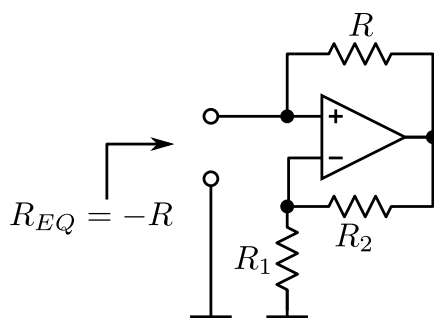

Figure 4: OpAmp implementation of a negative resistance.

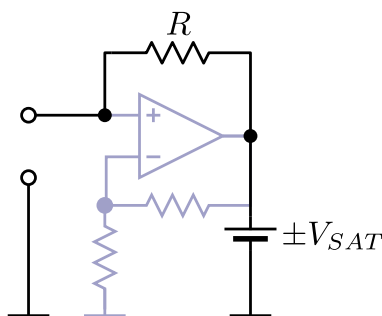

Figure 5: Equivalent circuit when the OpAmp is saturating.

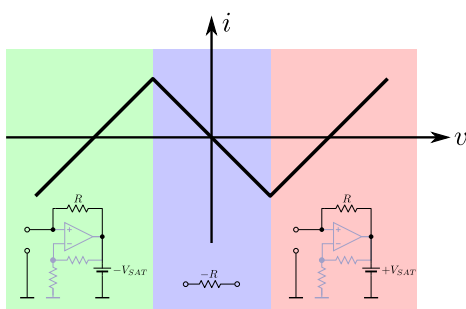

Figure 6: The full current-voltage, $i = f(v)$, characteristic of the negative resistance implemented with an OpAmp.

2 The Whole Circuit in Action

From the building blocks described up to now, we get the whole circuit, as depicted in figure 7. Its behavior may be explained as follows. You may refer to figure 8 for a sketch of the resulting signal $v_o(t)$.

- Initially, oscillations grow exponentially due to the negative resistance provided by the OpAmp circuit. 8a).
- When the signals are big enough, the OpAmp saturates (for convenience, let us consider that positive saturation is the first to occur). Now the equivalent circuit suddenly becomes a parallel LC circuit with only passive elements (positive resistors and a constant source).
- In this topology, the circuit is stable. Hence, the waveform, resulting from the initial conditions in L and C would decay to zero. 8b)
- However, as the signal decays, the OpAmp circuit behaves again as a negative resistance, providing an exponentially growing sinusoidal response that will translate into saturation. 8c)
- Once in negative saturation, the circuit is again passive and the whole procedure is repeated.
- Hence, the steady state is comprised of parts of a growing sinusoidal (each time $v_o(t)$ is in the central part of the i - v characteristic) with brief incursions into the zone where the OpAmp is saturated, yielding a damped sinusoidal. 8d)

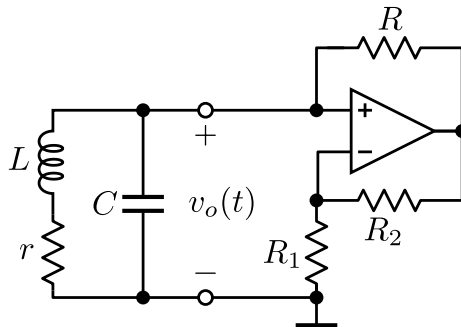

Figure 7: The full current-voltage characteristic of the negative resistance implemented with an OpAmp.

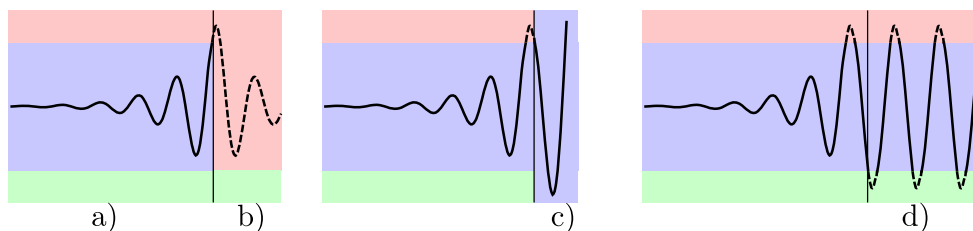

Figure 8: Behavior of the oscillator. Color codes as in figure 6.



From the previous explanation it is clear that the oscillator does *not* produce a pure sinusoidal signal. This is common to any oscillator as some kind of nonlinearity is unavoidable. But the resulting waveform is sufficiently clean from harmonics for a significant number of applications.

3 Laboratory work

Task 1. Build the circuit in figure 1 with $L = 22$ mH and $C = 100$ nF. Connect a constant source across the terminals and use the oscilloscope to view the resulting waveform.

Task 2. Build the circuit in figure 7 with the same L and C . Use $R_1 = R_2 = 10$ k Ω . Use a 10 k Ω potentiometer instead of R and adjust the value to achieve oscillation. Measure the oscillation frequency.

Task 3. Try to hear the signal with the provided loudspeaker. Build a voltage divider to not overdrive the amplifier or lower the power supply.

Task 4. Adjusting the circuit to be marginally stable, find out the value of r from the required value of R .

Task 5. Change the capacitor values (to 200 nF and 300 nF) and measure the oscillation frequency and the value of r

Task 6. Remove the capacitor. What happens? Can you explain that?